

BUMBLEBEE™
MISSILE LAUNCHER.

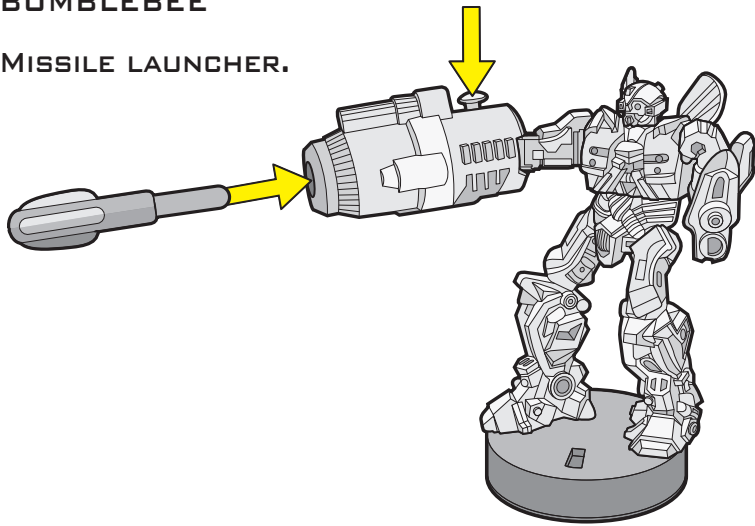

BONECRUSHER™
SWINGING ARM ATTACK.

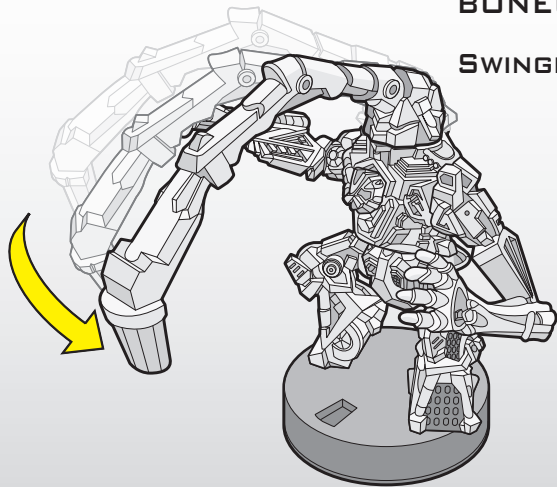

ATTACKTIX™
BATTLE
FIGURE GAME

TRANSFORMERS™

AGES 6+
68282/68249 ASST.

TOURNAMENT SET

INCLUDES FIGURE AND RULEBOOK
WITH QUICK-START GUIDE.

OPTIMUS PRIME™

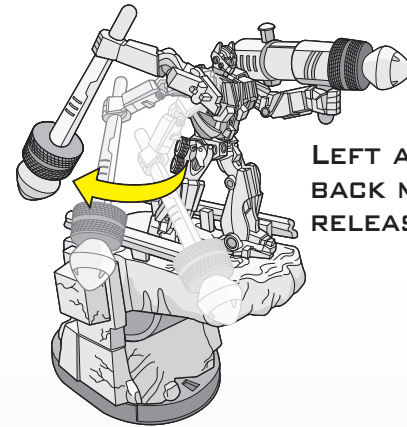

**LEFT ARM: PULL
BACK MAZE AND
RELEASE.**

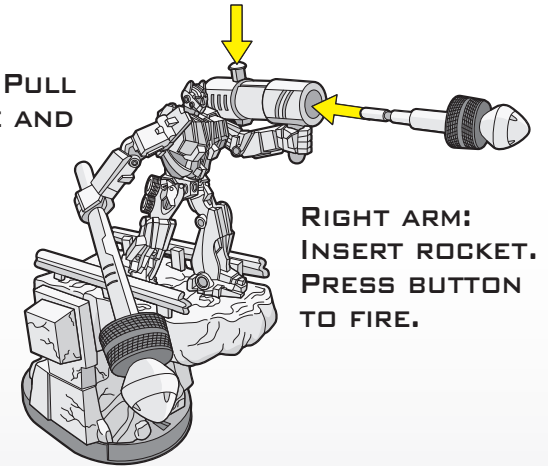

**RIGHT ARM:
INSERT ROCKET.
PRESS BUTTON
TO FIRE.**

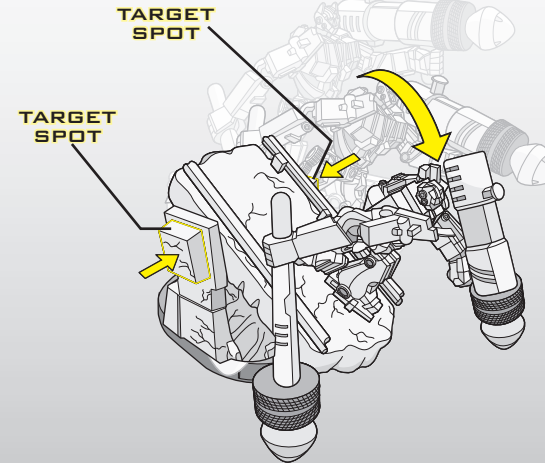

**TWO TARGET SPOTS -
OPPONENTS HIT BOTH SPOTS
TO KNOCK FIGURE OVER.**

NOTE: Must hit both target spots to knock figure over.

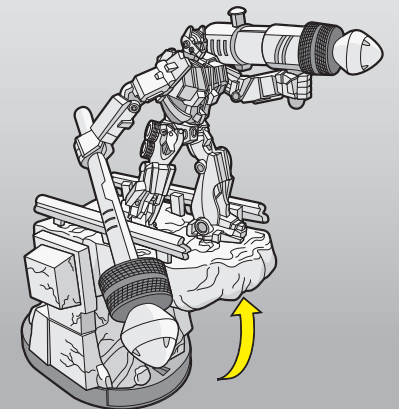

**TO RESET TO PLAY
POSITION, RAISE BRIDGE
TO ORIGINAL POSITION.**



P/N 669820000

Product and colors may vary.
© 2007 DreamWorks LLC and Paramount Pictures Corporation.
© 2007 Hasbro. All Rights Reserved.
TM & © denote U.S. Trademarks.
U.S. Pat. No. 7104543 and Patents Pending

attacktix.com



Not suitable for children under 3 years
because of small parts - choking hazard.

MEGATRON™

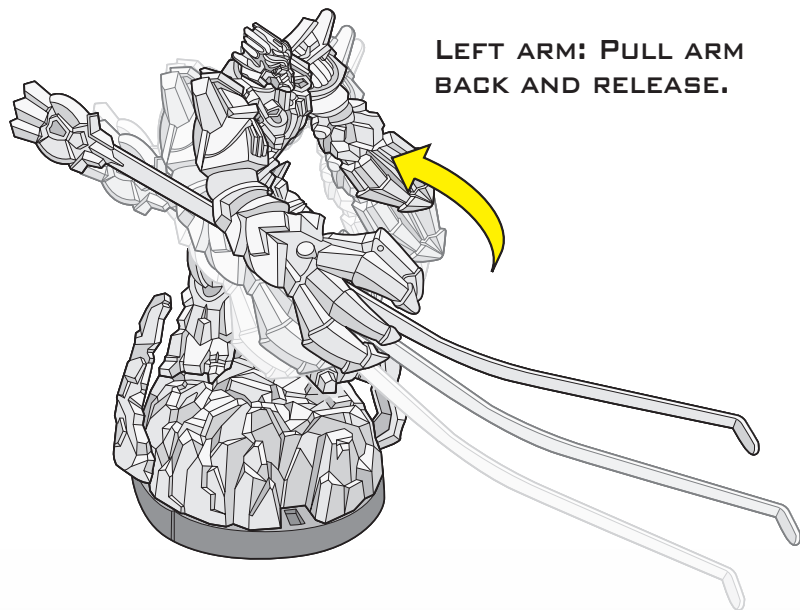

LEFT ARM: PULL ARM BACK AND RELEASE.

RIGHT ARM: PULL LEFT ARM BACK AND RELEASE SO THAT HOOK IS AGAINST OPPONENT'S FIGURE. PULL END OF HOOK BACK TO KNOCK FIGURE OVER.

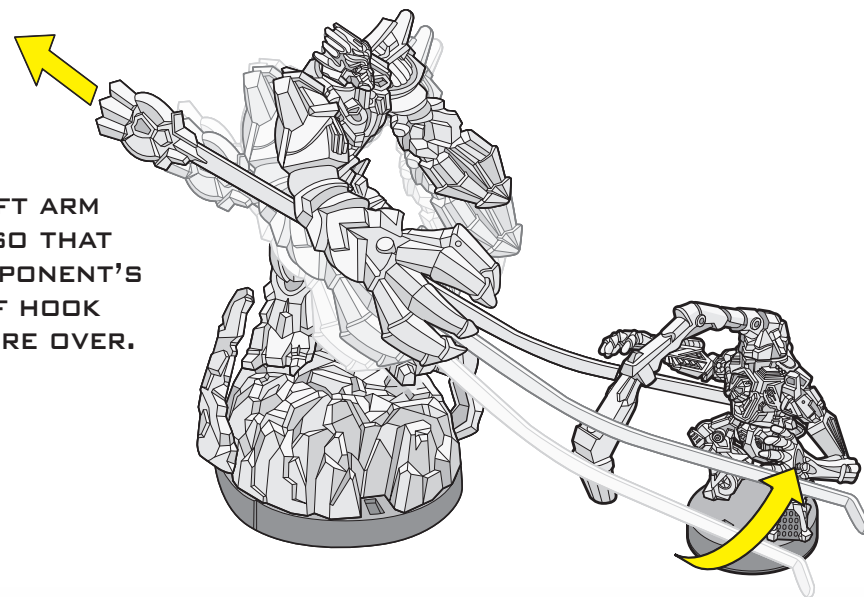

TARGET SPOTS: OPPONENTS HIT BOTH SPOTS TO KNOCK FIGURE OVER.

NOTE: Must hit both target spots to knock figure over.

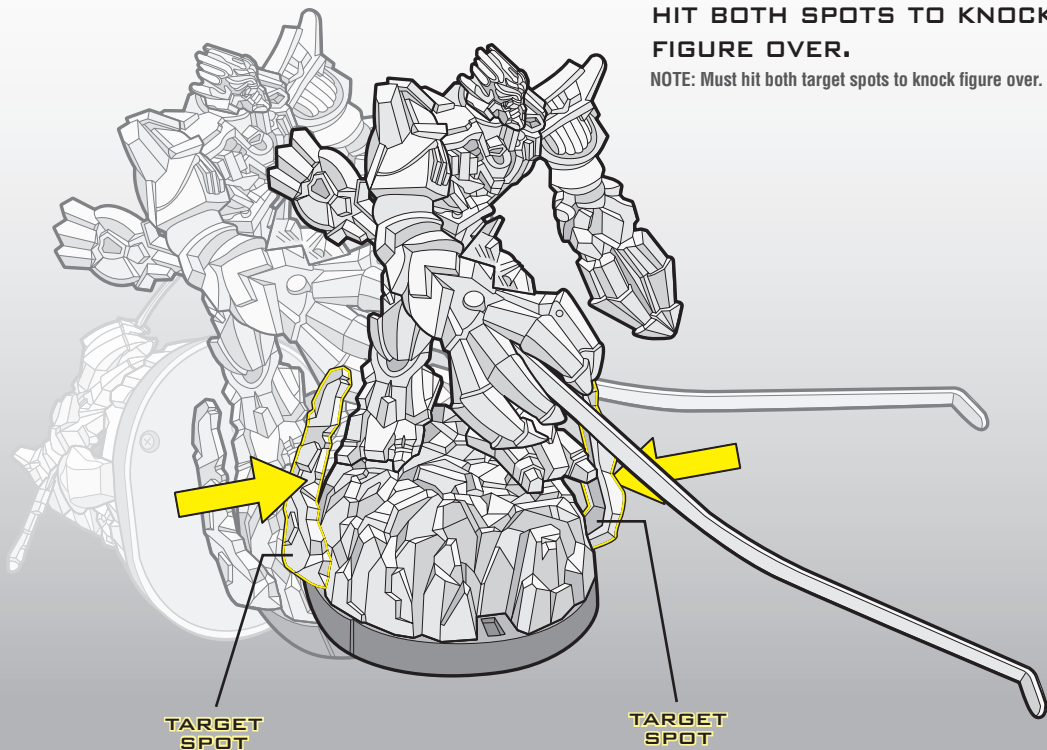

TARGET SPOT

TARGET SPOT

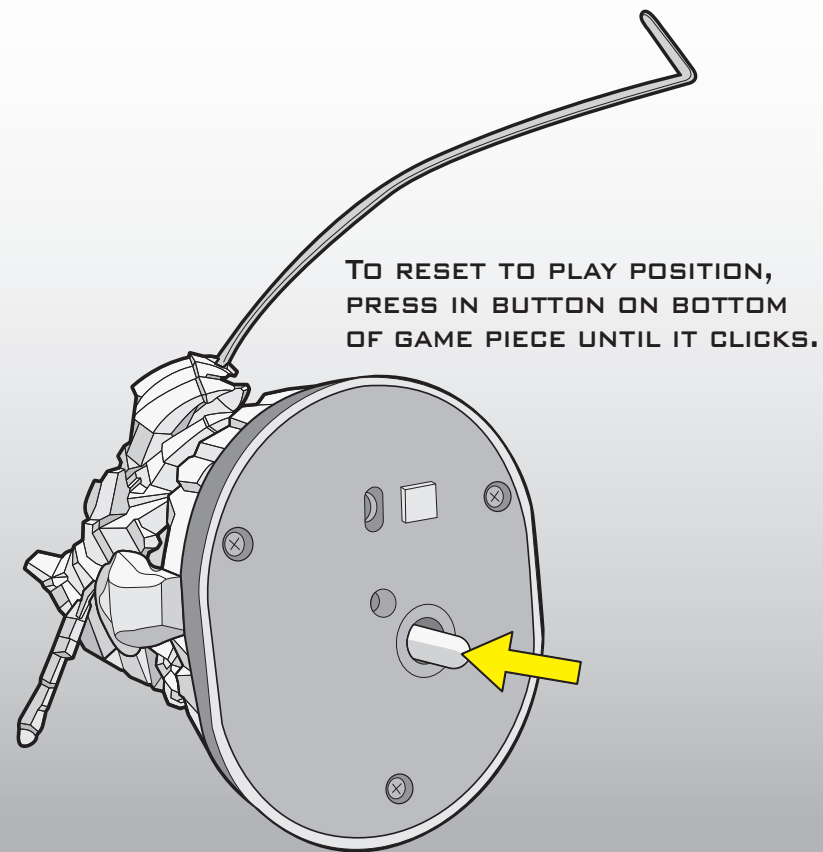

TO RESET TO PLAY POSITION, PRESS IN BUTTON ON BOTTOM OF GAME PIECE UNTIL IT CLICKS.